

Aluminum Die Cast

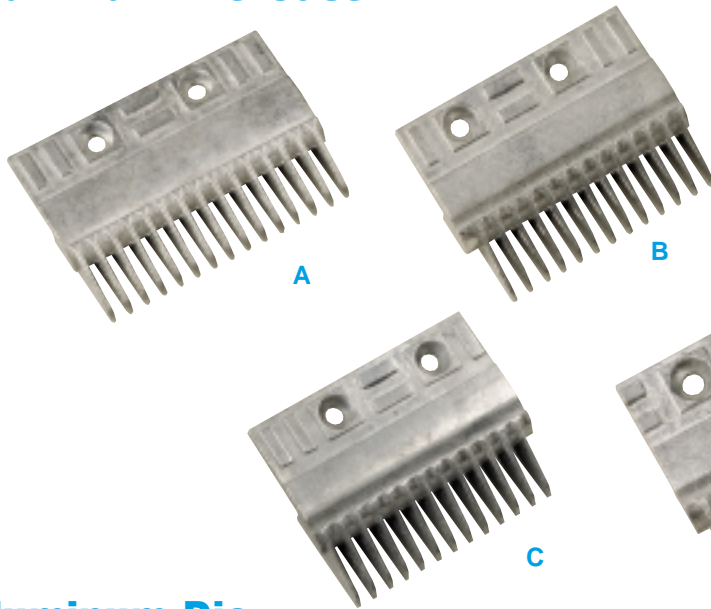

Key	ECS Number	Dimensions			Number Of Teeth
		d	x	y	
A.	H-63018	5"	1-1/2"	1-1/2"	15
B.	H-83085	4-1/2"	1-1/16"	1-1/2"	13
C.	H-83086	4-1/2"	1-1/2"	1"	13
D.	H-83083	2-1/2"	1"	1-1/2"	7
E.	H-83084	2-1/2"	1-1/2"	1"	7

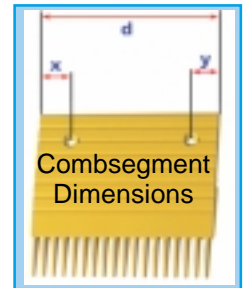

Aluminum Die Cast Yellow Finish

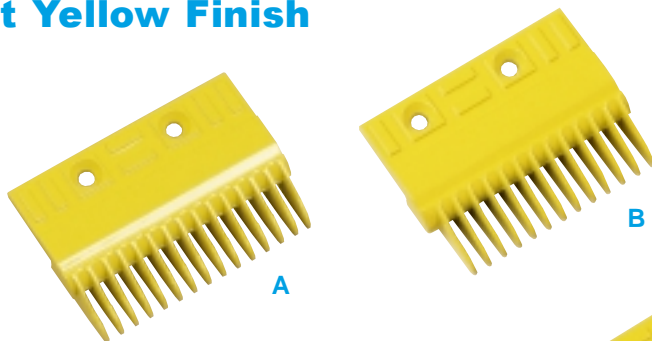

Key	ECS Number	Dimensions			Number Of Teeth
		d	x	y	
A.	H-63018YA	5"	1-1/2"	1-1/2"	15
B.	H-83085YA	4-1/2"	1-1/16"	1-1/2"	13
C.	H-83086YA	4-1/2"	1-1/2"	1"	13
D.	H-83083YA	2-1/2"	1"	1-1/2"	7
E.	H-83084YA	2-1/2"	1-1/2"	1"	7

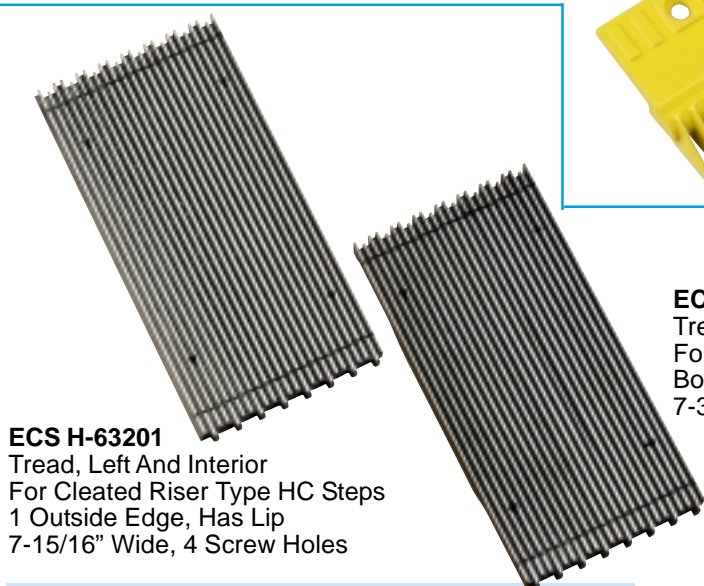
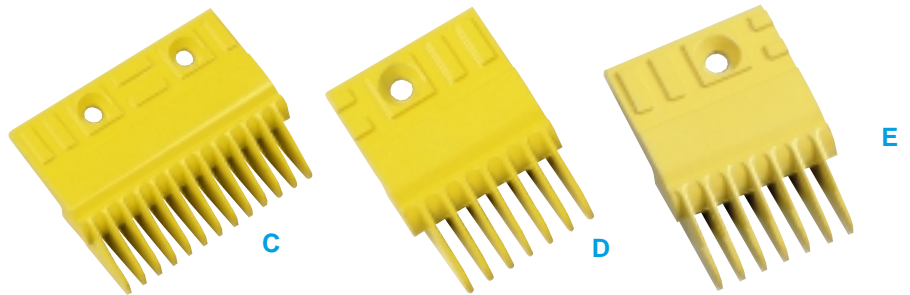

ECS H-63201
Tread, Left And Interior
For Cleated Riser Type HC Steps
1 Outside Edge, Has Lip
7-15/16" Wide, 4 Screw Holes

ECS H-63242
Tread, Right
For Cleated Riser Type HC Steps
Both Outside Edges Are Smooth
7-3/4" Wide, 4 Screw Holes

ECS H-73848
Bracket, Right Hand
For HC Cleated Riser Step
Includes Pin, Spring, Hardware
and H-97444 Roller



ECS H-93031
Screws, For Treads H-63201
And H-63242.
25 Pieces Per Package

ECS H-73847
Bracket, Left Hand
For HC Cleated Riser Step
Includes Pin, Spring, Hardware
and H-97444 Roller

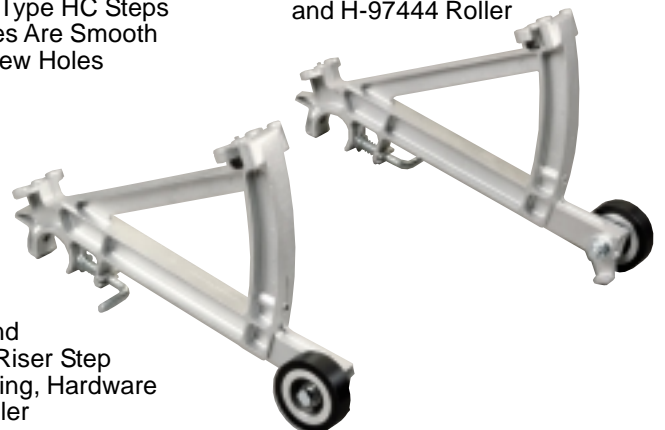



ECS H-73831
Step Chain For HC Units
1 Pair, Each Pair
Accommodates 6 Steps



ECS H-90936
Bushing Used on H-71100
Extended Pins
3/4" O.D. x 7/16" I.D.
1" Long



ECS H-71100
Step Chain for CD Units
Extended Pin Every 11th Pitch
On 16" Centers



The **EscaLight** is an ideal replacement for under step, demarcation fluorescent bulbs. While using low voltage, the "cool to the touch" EscaLight emits a bright and continuous green light rated for 57,000 hours or **6.5 years** of use.

ECS DL240P
plastic molded housing is completely sealed, extremely durable, resists vibration and withstands water, oil, dirt and dust.



ECS DL240

The EscaLight is assembled in a rugged steel channel. The transformer is housed in a weather resistant, plastic enclosure and the wiring is encased in water resistant conduit. Simply run an electrical source to the transformer and your DL240 is ready to go.

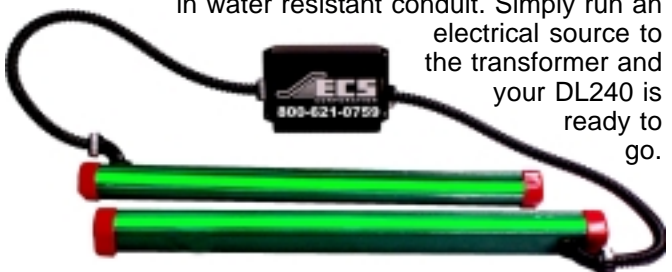

Rollers



ECS H-97444
Roller, Step Trail
3" O.D. x 1" Tire Face
5/8" Bearing I.D.



ECS H-97662
Roller, Step or Chain
3-1/2" O.D. x 1" Tire Face
3/4" Bearing I.D.